

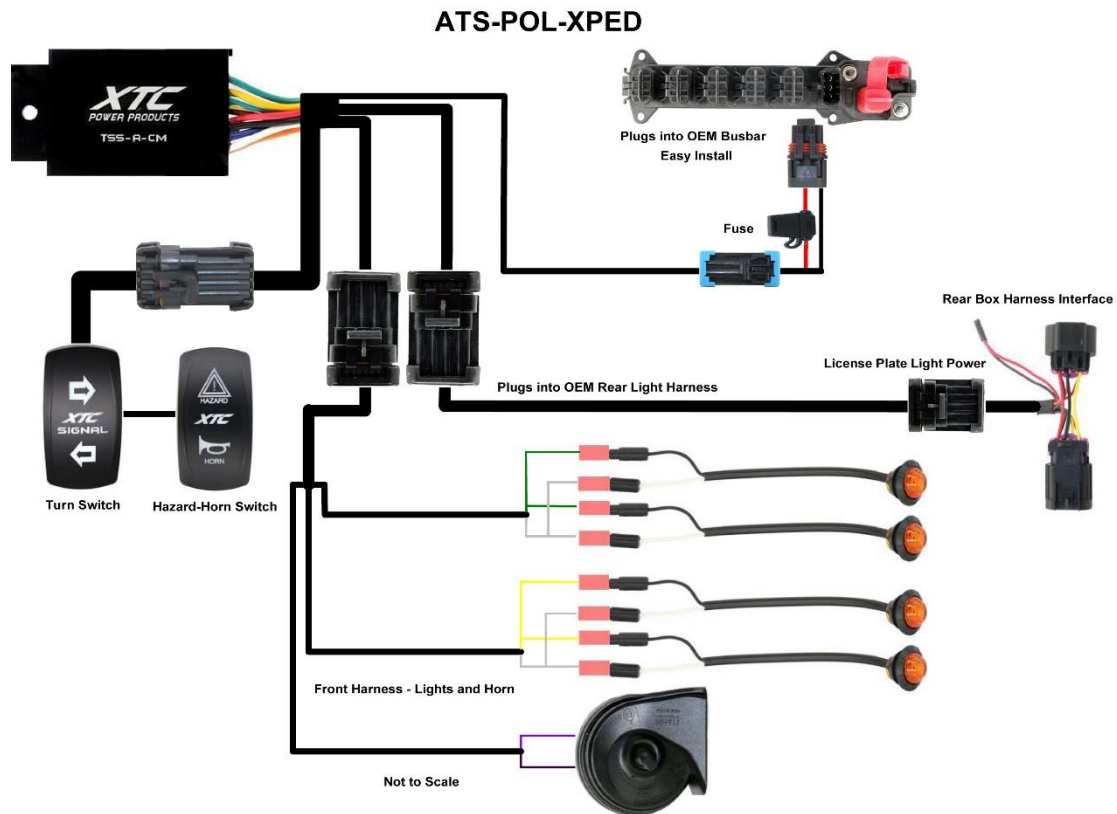

Polaris Xpedition Turn Signal System

Thank you for purchasing XTC Power Products Automatic Self-Canceling Turn Signal System. Our Easy-Install Turn Signal System is unique from the other kits on the market. This kit is from our Plug & Play™ product line, no wires to cut, no crimping, plugs into OEM Pulse Power System for Power. We use our Patented System that plugs into the OEM Taillights, utilizing the Brake Lights as Brake and Turn Signals.

Please read the instructions fully and familiarize yourself with the components before starting the installation. The diagram below shows the overall system layout.



1. Install Rear Light Harness – Lift up the dump bed. In the middle rear over the motor is a 8-way connector, un-plug that connector and install the PPA TS-POL-GTX-REAR harness in line. The 4-way connector should be pointed up.



2. Remove the Hood and mount the control unit under the hood as shown using the included screw.



3. Install the extension harness PPA TS-REAR-15EXT. It is run from the rear harness up to under the hood. Remove the drivers' side front fender and side plastics. Plug the extension into the main control unit to verify which direction the harness should go. Push the other end with the female connector (shown above right) into the grommet and feed through the dash over to the driver's side kick panel/fender well as shown below.

WARNING! Make sure to keep the harness away from any hot or moving parts.



Run the harness in the frame housing to the rear and up over the motor and plug into the rear light harness.



Secure the harness using the provided cable ties.

WARNING! Verify that there is clearance where you want to mount the front LED lights before drilling the holes!

4. Front LED Turn Lights – The front LED Turn Indicators can be mounted with the rubber grommet or without. If the grommet is **not** being used drill 5/8" holes. If the grommet is being used drill 3/4" holes. Remove and install the rubber grommet from the LED into the hole if being used. Insert LED into the hole with the Top marking up. NOTE: the TOP marking is on the front of the LED lens. Drill and install the Front LED Lights.

In the example, we drilled the 5/8" hole in the front and one in the reflector support.

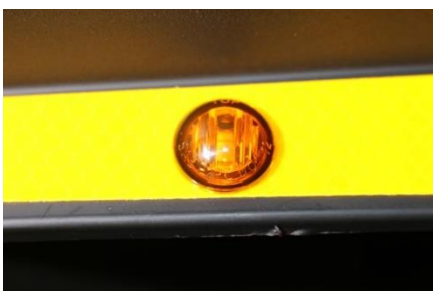



5. Install front wire harness – Plug the harness into the control unit. Run the yellow wires to the driver’s side LED’s and the green wires go to the passenger side LED’s. The wires go under the fender, there is a hole down alongside the headlight that the wires can be run through. We drilled extra holes on each side to help run the wires.

NOTE: The Black LED wire is positive and goes to the yellow and green wires, they will not work if reversed, white is ground. Secure the Harness using the provided cable ties.

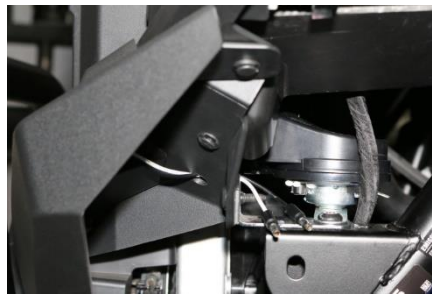
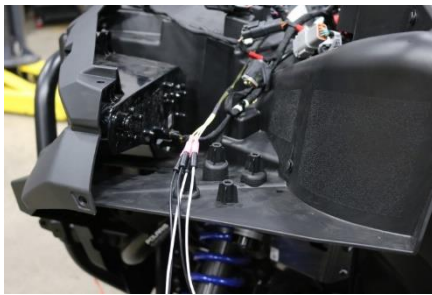

6. Install the Horn. Remove the Torx screw that hold the plastic to the frame in the wheel well. Install the horn as shown. Connect the Violet and Black wire to horn terminals, position does not matter.



7. Install the Turn and Horn/Hazard Switches. Remove 2 of the switch plugs in the positions you would like to use.



Run Switch Harness—Run the large switch connector from inside the dash, through the rubber grommet and Plug into the Control Module, run the two connectors through the rectangle switch cutouts and use included grease on the terminals then connect to turn switch and Hazard/Horn, slide switches into dash.

8. Plug the 2-way Power Harness into the Control Module. Run the power wire to the Busbar, remove one of the blanks and plug into the factory Pulse Busbar.

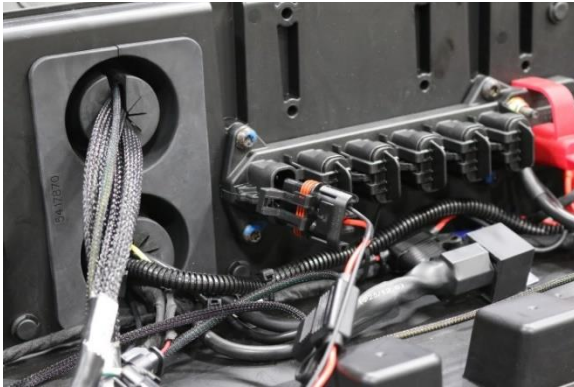

9. **Verify Operation:** The System uses momentary switches to activate. Turn the car key to the on position, Press the Right or Left Actuator accordingly. You can cancel the signal at any time by pushing the activated switch a second time or it will cancel as follows:

Press 1 Second for Lane Change, will stay on approx. 8 Seconds / 10 Flashes

Press 2 Seconds for Slowing to Turn Corners, will stay on approx. 20 Seconds / 30 Flashes

Press 5 Seconds for Traffic Lights when stopping and waiting, will stay on approx. 75 Seconds / 110 Flashes

The Systems Automatic Self-Cancelling may be overridden/Shut Off at any time by pushing the activated switch.

Hazard Lights - press to activate and press again to deactivate, it does not self-cancel. Test the Horn

10. Using the provided Cable Tie's secure the harness completely. Reinstall any removed parts.

We can be reached by email at support@xtcpowerproducts.com

XTC Power Products
A Division of XTC Motorsports LLC
380 E Comstock Dr.
Chandler AZ 85225
480-558-8588
www.xtcpowerproducts.com

*Disclaimer: This kit is intended for off road use only and XTC Motorsports claims no responsibility for its use. It is up to the purchaser to make sure it complies with all Federal, State and Local laws. R1

Copyright © 2023 XTC MOTORSPORTS LLC, all rights reserved.