



ATS-POL-XP16 RZR XP TURN SIGNAL SYSTEM

Thank you for purchasing XTC Power Products Automatic Self-Canceling Turn Signal System. Our Easy Install Turn Signal System is unique from the other kits on the market. This kit is from our Plug & Play™ product line, no wires to cut, no crimping with only power, ground and plugs into the OEM Tail Light Harness, utilizing the brake lights as Brake and Turn Signals.

ATS-POL-XP16 Fits 2015-2018 RZR XP's 2 Seat and 4 seats, both Turbo and Non-Turbo, RZR 900S, 1000S

Please read the instructions fully and familiarize yourself with the components before starting the install.

ATS-POL-XP16 Automatic Self-Canceling Turn Signal System

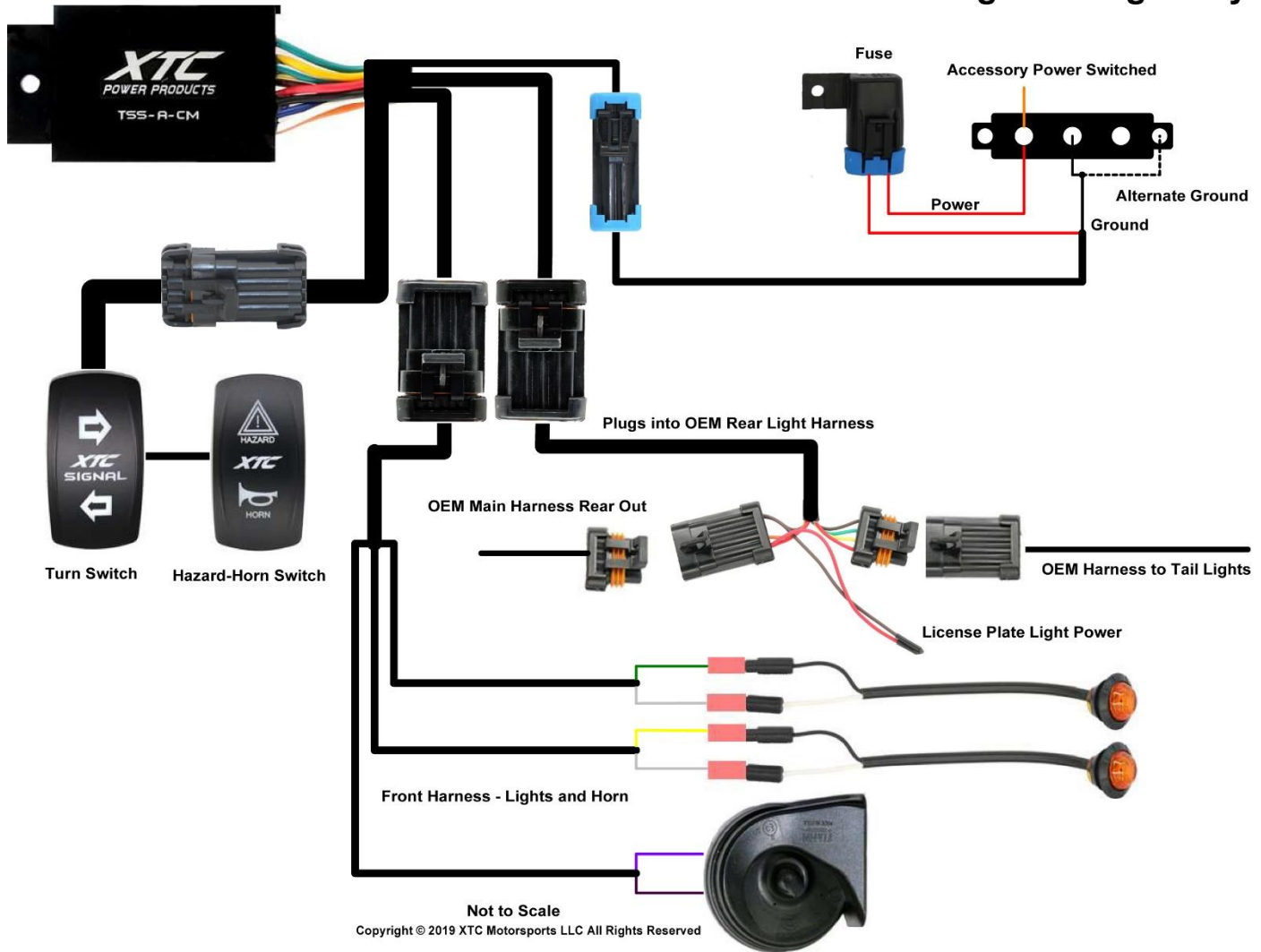

System Diagram

1. **Remove the hood** - and remove two Torx screws and remove dash cover.
2. **Mount Control Module** under dash on the center cross bar with supplied self-tapping screw.
3. **Plug rear Harness into OEM Connector** - Unplug wire harness at rear left side and connect our harness, see photo below. (Note: There is a Red and Black power wire provided for an optional license plate light).



Stock Connector



XTC Harness connector installed

4. **Run Rear Harness** - There are two ways you can run the harness, under skid plate along the brake line OR inside center hump along seat belt anchors by removing the seats and center plastics. Starting from the Rear of the car at the OEM Rear Light Connector, Run the long harness with the single 4 Pin Connector through the center of the car (either way as stated above) up the outside of the firewall through the rubber grommet to the Control Module and plug in. **Secure cable using the supplied cable tie's making sure to keep the harness away from any Hot or Moving parts.**



WARNING! Verify that there is clearance before drilling holes for the LED's or switches.

5. **Install Front LED Turn Lights** – The front LED Turn Indicators can be mounted with the rubber grommet or without. If the grommet is **not** being used drill 5/8" holes. If the grommet is being used drill 3/4" holes. Remove and install the rubber grommet from the LED into the hole if being used. Insert LED into the hole with the Top marking up. NOTE: the TOP marking is on the front of the LED lens.



Run the short front harness through rubber grommet to the front right LED. Connect the green wire to the black and the white to white, continue harness to left LED, yellow wire attaches to black wire and the white wire goes to white. NOTE: Black wire is positive and will not work if reversed. White is ground. Secure the Harness using the provided cable ties.

WARNING! Verify that there is clearance behind dash for switch's.

6. **Install Turn Switch** - Using the provided switch template, mark the rectangle for the switch and drill a hole in each corner, using a sharp box knife cut out the rectangle, do not over cut, trim as necessary. Push the switch Connector and wires through and apply grease (see Below) attach to switch and install in dash.



Dielectric Grease - Just like the OEM uses on their switches, we recommend using Dielectric Grease on all switch terminals, this keeps the water out, thereby reducing corrosion and helps increase reliability! Open the grease and put on the switch terminals and the connector terminals on both the Turn and Horn switches, the more the better.

7. **Install Hazard Horn Switch** - Using the provided switch template, mark the rectangle for the switch and drill a hole in each corner, using a sharp box knife cut out the rectangle. Push the switch Connector and wires through and apply grease (see Below) attach to switch and install in dash.
8. Remove the bolt from the radiator support bracket and mount horn and ground wire as shown. Run the purple wire through the grommet on the fire wall and attach to horn. For Turbo's remove the Torx screw holding the body and install bracket between plastics and re install screw.



9. Run power wire to 12vdc accessory stud under the hood and ground the black wire to the Busbar screw. **Note: 2015 and 2016 RZR's do not have a ground hooked on the factory Busbar stud under the hood unless the power up kit was installed.**

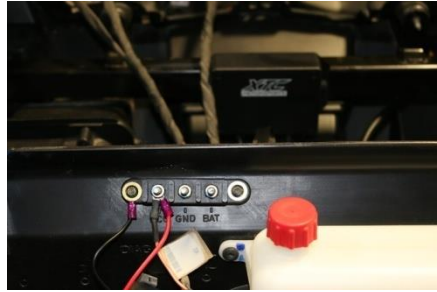

10. Verify operation of all lights.
11. Cable tie any extra harness under dash
12. Reinstall dash cover, hood, center tunnel and seats or skid plates if removed.

Operation: The System uses momentary switches to activate. Press Right or Left Actuator accordingly. Will cancel as follows.

Press 1 Second for Lane Change, will stay on approx. 8 Seconds / 10 Flashes

Press 2 Seconds for Slowing to Turn Corners, will stay on approx. 20 Seconds / 30 Flashes

Press 5 Seconds for Traffic Lights when stopping and waiting, will stay on approx. 75 Seconds / 110 Flashes

The Systems Automatic Self-Cancelling may be overridden/Shut Off at any time by pushing the activated switch.

Hazard Lights - press to activate and press again to deactivate, it does not self-cancel.

We can also be reached by email at support@xtcpowerproducts.com

XTC Power Products
A Division of XTC Motorsports LLC
380 E Comstock Dr.
Chandler AZ 85225
480-558-8588
www.xtcpowerproducts.com

*Disclaimer: This kit is intended for off road use only and XTC Motorsports claims no responsibility for it use. It is up to the purchaser to make sure it complies with all Federal, State and Local laws

R3

Copyright © 2023 XTC MOTORSPORTS LLC, all rights reserved.